

OPzS Series Battery

SPACEFLIGHT OPzS Series battery is Tubular Flooded battery, designed with an innovative tubular plates which provide greater capacity and enhanced cycle life. The battery has been specifically designed for longer life, greater reliability and strong resilience to high temperature making them ideal for critical power applications and energy storage.

Applications

- Solar and wind power systems
- Uninterruptible power supplies
- Communication systems
- Telecommunication systems
- Emergency Power Systems

General Features

- 20 years designed floating life(25°C)
- Non-spillable construction
- Sealed and maintenance-free
- Advanced tubular positive plates
- Excellent recovery from deep discharge
- Longer Life and low self-discharge

Standards

- Compliance with IEC, BS, JIS and EU standards.
- UL, CE Certified
- ISO45001,ISO9001 and ISO14001 certified production facilities

Specifications

| | | |
|---------------------------------|---|---|
| Rated Voltage | 2V | |
| Nominal Capacity | 1500Ah | (C ₁₀ , 1.8V) |
| Approx Weight | Without Electrolyte 80.3kg/With Electrolyte 114.3kg | |
| Terminal | F28 | |
| Rated Capacity(25°C) | 2196 Ah | (240hr,9.10A,1.85V) |
| | 1800 Ah | (100hr,18.0A,1.85V) |
| | 1500 Ah | (10hr,150.0A,1.80V) |
| | 1260 Ah | (5hr,252.0A,1.80V) |
| Max.Discharge/Charge Current | 7500A(5s)/375A | |
| Max.Short Circuit Current | 9600A | |
| Internal Resistance(25°C) | Approx 0.32mΩ | |
| Operating Temp.Range | Discharge | -20~60°C(-4~140°F) |
| | Charge | -10~50°C(14~122°F) |
| | Storage | -20~60°C(-4~140°F) |
| Nominal operating temperature | 25±5°C | |
| Charge Voltage @25°C(77°F) | Cycle Use | Initial Charging Current less than 375A. Voltage 2.4V~2.45V at 25°C(77°F)Temp. Coefficient -5mV/°C |
| | Standby Use | Initial Charging Current less than 375A. Voltage 2.23V~2.25V at 25°C(77°F)Temp. Coefficient -3mV/°C |
| Temperature effects on capacity | 40°C (104°F) | 103% |
| | 25°C (77°F) | 100% |
| | 0°C (32°F) | 86% |
| | -15°C (5°F) | 65% |
| Self Discharge(25°C) | Capacity after 3 months storage | 91% |
| | Capacity after 6 months storage | 82% |
| | Capacity after 12 months storage | 65% |



Dimensions

unit:mm

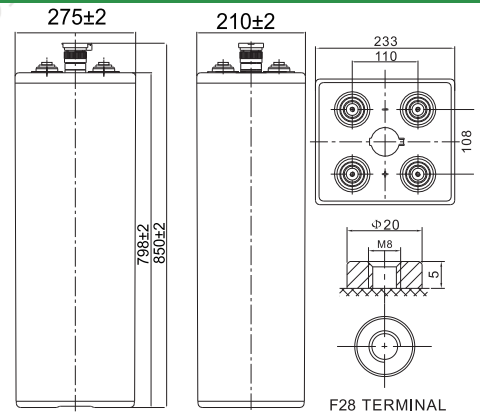

| | |
|------------------|-----------------------|
| Length | 275±2mm (10.8 inches) |
| Width | 210±2mm (8.27 inches) |
| Container Height | 798±2mm (31.3 inches) |
| Total Height | 850±2mm (33.4 inches) |

Battery Construction

| Component | Positive plate | Negative plate | Container | Safety valve | Terminal | Separator | Electrolyte |
|--------------|----------------|----------------|-----------------------------|--------------|----------|-----------|---------------|
| Raw material | Lead dioxide | Lead | ABS(UL94-HB) or FR(UL94-V0) | Rubber | Copper | PVC | Sulfuric acid |

Constant Current Discharge (Amperes) at 25°C(77°F)

| E.V/Time | 1h | 3h | 5h | 10h | 24h | 48h | 100h | 120h | 240h |
|----------|-----|-----|-----|-----|-------|-------|-------|-------|-------|
| 1.70V | 746 | 383 | 261 | 153 | ----- | ----- | ----- | ----- | ----- |
| 1.75V | 705 | 375 | 255 | 153 | 79.5 | 43.5 | ----- | ----- | ----- |
| 1.80V | 660 | 356 | 252 | 150 | 78.0 | 43.5 | ----- | ----- | ----- |
| 1.85V | 648 | 348 | 237 | 146 | 76.5 | 42.0 | 18.0 | 15.6 | 9.10 |
| 1.90V | 608 | 330 | 230 | 140 | 72.0 | 40.5 | 17.7 | 15.3 | 9.00 |

Constant Power Discharge (Watts/cell) at 25°C(77°F)

| E.V/Time | 1h | 3h | 5h | 10h | 24h | 48h | 100h | 120h | 240h |
|----------|------|-----|-----|-----|-------|-------|-------|-------|-------|
| 1.70V | 1389 | 714 | 489 | 296 | ----- | ----- | ----- | ----- | ----- |
| 1.75V | 1316 | 704 | 482 | 296 | 159 | 87.8 | ----- | ----- | ----- |
| 1.80V | 1235 | 669 | 477 | 294 | 156 | 87.0 | ----- | ----- | ----- |
| 1.85V | 1221 | 662 | 456 | 288 | 153 | 84.8 | 36.6 | 31.8 | 18.8 |
| 1.90V | 1161 | 635 | 446 | 279 | 145 | 82.5 | 36.0 | 31.4 | 18.5 |

Note: The above characteristics data are average values obtained Within three charge/discharge cycles not the minimum.

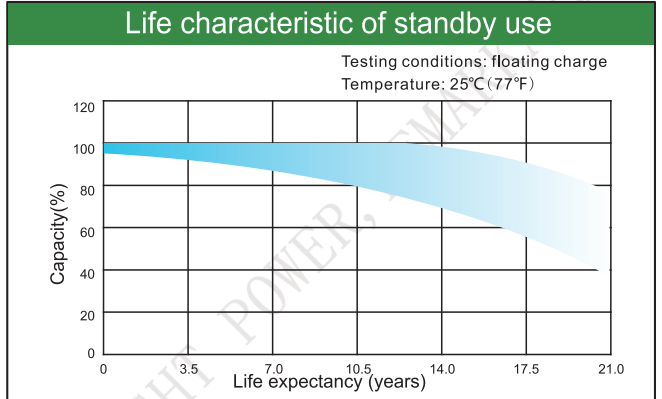
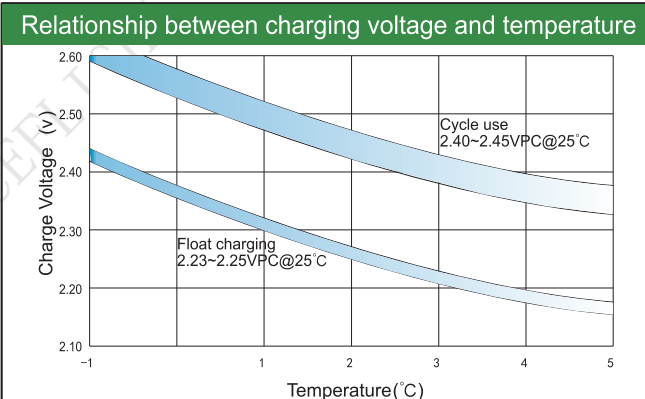
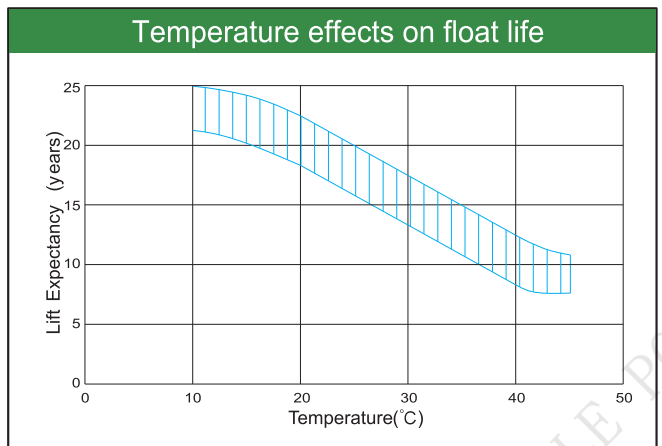
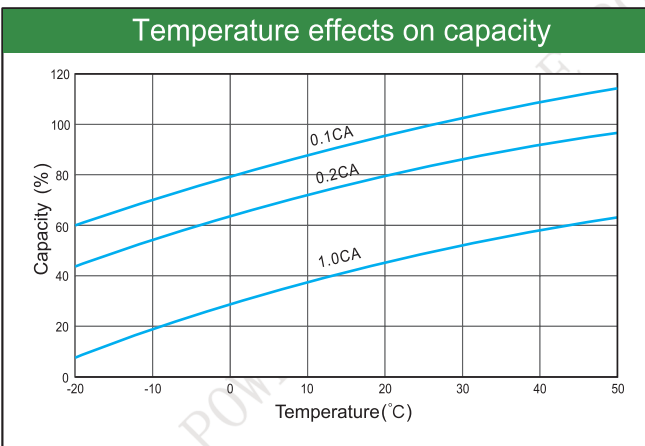
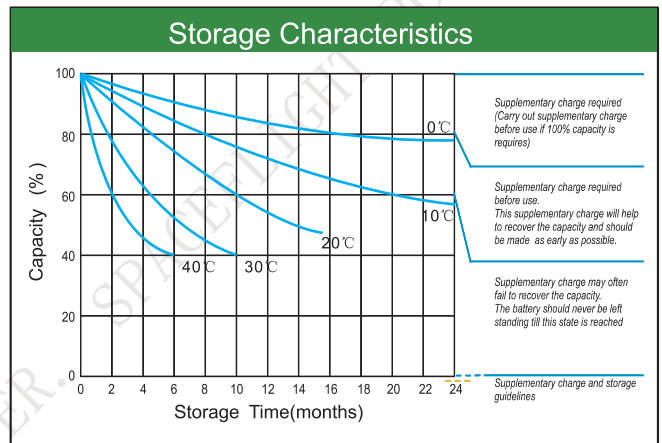
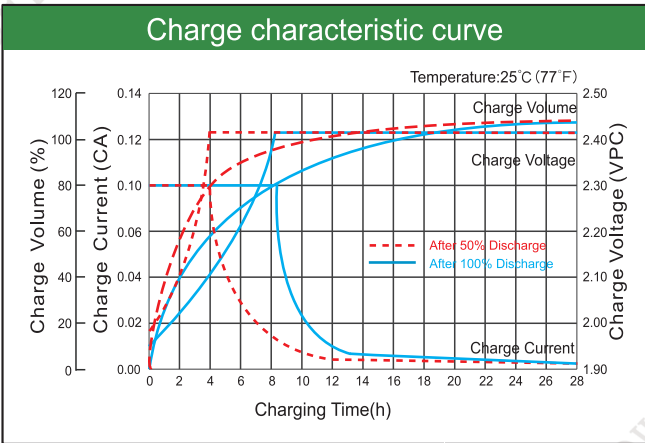
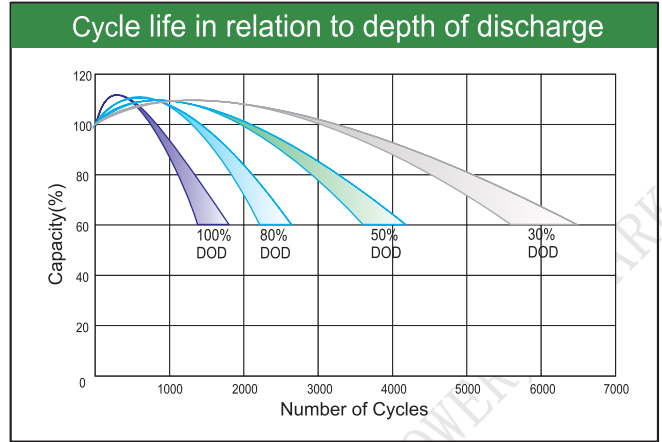
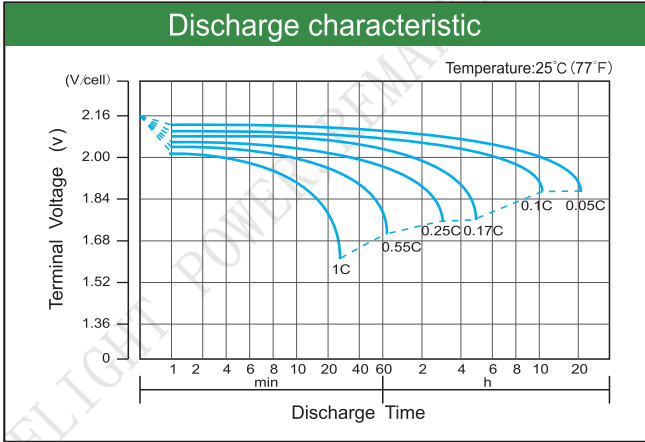

Factory address: Fukang Industrial Zone, Longnan, Ganzhou, Jiangxi Province, China.
 Shenzhen Office: RM208-210, Building D, Tongju industrial Park, No.4, Longping West Road, Longgang District, Shenzhen.
 TEL: +86-755-28288189 sales@sfbattery.com www.sfbattery.com