

EV U1 MF Series Battery

EV U1 MF series battery is Deep Cycle battery specially designed for frequently charge and discharging application. By using heavy duty grids, thicker plates and specially active materials, which the battery can offer 30% more cycle life than general AGM batteries, they are special design for Garden machinery power application.

Applications

- Garden Machinery
- Golf carts and Wheelchairs
- Floor Sweepers and Electric Vehicles

General Features

- Non-spillable construction
- Sealed and maintenance-free
- Excellent recovery from deep discharge
- High density active materials plates
- Vibration Resistance

Standards

- Compliance with IEC, BS, JIS and EU standards.
- UL, CE Certified
- ISO45001,ISO9001 and ISO14001 certified production facilities

Specifications

Rated Voltage	12V	
Nominal Capacity	25Ah	(C ₂₀ , 10.5V)
Approx Weight	7.5kg±3%(16.5lbs)	
Terminal	T4	
Rated Capacity(25°C)	25Ah	(20hr, 1.25A, 10.5V)
	20.8Ah	(5hr, 4.16A, 10.5V)
	18.3Ah	(3hr, 6.1A, 9.6V)
Max.Discharge Current	250A(5s)	
Max.Charge Current	6.25A	
Operating Temp.Range	Discharge	-20~60°C(-4~140°F)
	Charge	-10~50°C(14~122°F)
	Storage	-20~60°C(-4~140°F)
Nominal operating temperature	25±5°C	
Charge Voltage @25°C(77°F)	Cycle Use	Initial Charging Current less than 6.25A. Voltage 14.4V~15.0V at 25°C(77°F).
	Standby Use	Initial Charging Current less than 6.25A. Voltage 13.5V~13.8V at 25°C(77°F).
Temperature effects on capacity	40°C (104°F)	103%
	25°C (77°F)	100%
	0°C (32°F)	86%
	-15°C (5°F)	65%
Self Discharge(25°C)	Capacity after 3 months storage	91%
	Capacity after 6 months storage	82%
	Capacity after 12 months storage	65%
CCA (EN50342)	270A	
STORAGE CAPACITY:(DISCHARGE WITH 20A TO 10.5V)	40Ah	



Dimensions

unit:mm

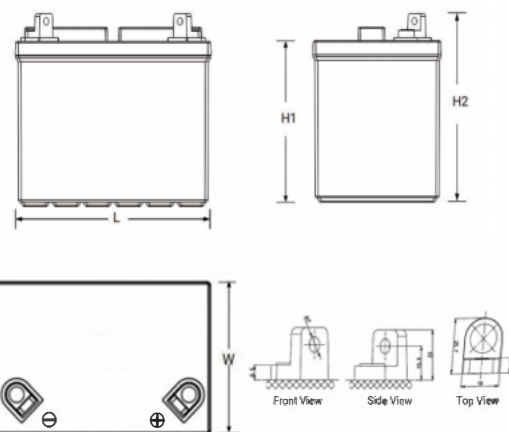

Length	195±2mm (7.68 inches)
Width	130±2mm (5.12 inches)
Container Height	161±2mm (6.34 inches)
Total Height	183±2mm (7.20 inches)

Battery Construction

Component	Positive plate	Negative plate	Container	Safety valve	Terminal	Separator	Electrolyte
Raw material	Lead dioxide	Lead	PP	Rubber	LEAD	PE	Sulfuric acid

Factory address: Fukang Industrial Zone, Longnan, Ganzhou, Jiangxi Province, China
 Shenzhen Office: RM208-210, Building D, Tongju Industrial Park, No.4, Longping West Road, Longgang District, Shenzhen.
 TEL:+86-755-28288189 sales@sfbattery.com www.sfbattery.com