

HTD Series Battery

SPACEFLIGHT HTD series battery is Deep Cycle AGM battery designed with thicker plates with more high-density active materials which makes the battery can with stand repeated deep cyclic applications.

Applications

- Solar and wind power systems
- Communication systems
- Uninterruptible power supplies
- Golf carts and buggies
- Alarm and security system
- Electric toy and wheelchairs, etc

General Features

- 10 years designed floating life(25°C)
- Non-spillable construction
- Sealed and maintenance-free
- Excellent recovery from deep discharge
- High density active materials plates
- Longer Life and low self-discharge

Standards

- Compliance with IEC, BS, JIS and EU standards.
- UL, CE Certified
- ISO45001,ISO9001 and ISO14001 certified production facilities

Specifications

Rated Voltage	12V	
Nominal Capacity	100Ah	(C ₁₀ , 10.8V)
Approx Weight	29.5kg±3%(65.04lbs)	
Terminal	F12	

Rated Capacity(25°C)	106 Ah	(20hr,5.3A, 10.5V)
	100 Ah	(10hr, 10A, 10.8V)
	87 Ah	(5hr, 17.4A, 10.5V)
	63.5 Ah	(1hr, 63.5A, 9.6V)

Max.Discharge Current 1000A(5s)

Max.Charge Current 25A

Internal Resistance(25°C) Approx 6mΩ

Operating Temp.Range	Discharge	-20~60°C(-4~140°F)
	Charge	-10~50°C(14~122°F)
	Storage	-20~60°C(-4~140°F)

Nominal operating temperature 25±5°C

Charge Voltage @25°C(77°F)	Cycle Use	Initial Charging Current less than 25A. Voltage 14.4V~15.0V at 25°C(77°F)Temp. Coefficient -30mV/°C
	Standby Use	Initial Charging Current less than 25A. Voltage 13.5V~13.8V at 25°C(77°F)Temp. Coefficient -20mV/°C

Temperature effects on capacity	40°C (104°F)	103%
	25°C (77°F)	100%
	0°C (32°F)	86%
	-15°C (5°F)	65%

Self Discharge(25°C)	Capacity after 3 months storage	91%
	Capacity after 6 months storage	82%
	Capacity after 12 months storage	65%



Dimensions

unit:mm

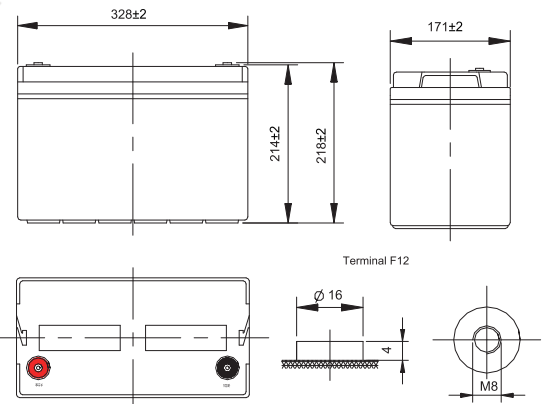

Length	328±2mm (12.90 inches)
Width	171±2mm (6.74 inches)
Container Height	214±2mm (8.43 inches)
Total Height	218±2mm (8.66 inches)

Battery Construction

Component	Positive plate	Negative plate	Container	Safety valve	Terminal	Separator	Electrolyte
Raw material	Lead dioxide	Lead	ABS(UL94-HB) or FR(UL94-V0)	Rubber	Copper	Fiberglass	Sulfuric acid

Constant Current Discharge (Amperes) at 25°C(77°F)

E.V/Time	5min	10min	15min	30min	60min	3h	5h	10h	20h
1.60V	323	221	182	103	63.5	26.5	18.2	10.3	5.40
1.65V	296	207	173	99.0	62.5	26.0	18.0	10.3	5.40
1.70V	270	192	164	96.0	61.5	25.5	17.7	10.2	5.35
1.75V	242	179	153	93.0	60.5	24.9	17.4	10.1	5.30
1.80V	214	164	143	91.0	59.5	24.3	17.0	10.0	5.20

Constant Power Discharge (Watts/cell) at 25°C(77°F)

E.V/Time	5min	10min	15min	30min	45min	60min	2h	3h	5h
1.60V	556	392	320	194	144	124	70.3	49.6	34.7
1.65V	517	372	315	188	140	122	69.1	49.0	34.5
1.70V	478	353	305	183	137	121	67.8	48.5	34.2
1.75V	447	334	294	177	134	117	66.6	47.9	34.0
1.80V	401	312	284	171	131	114	65.9	47.1	33.7

Note: The above characteristics data are average values obtained Within three charge/discharge cycles not the minimum.

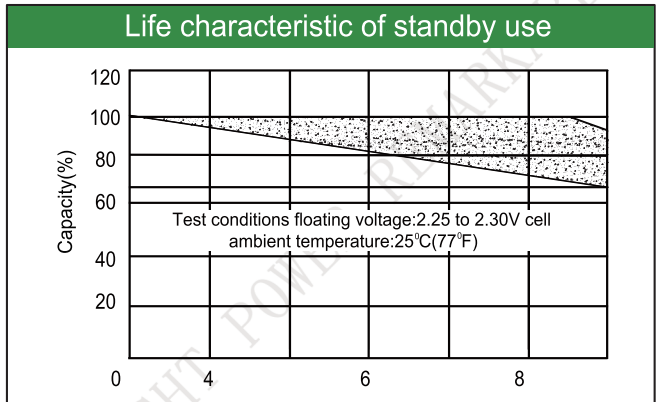
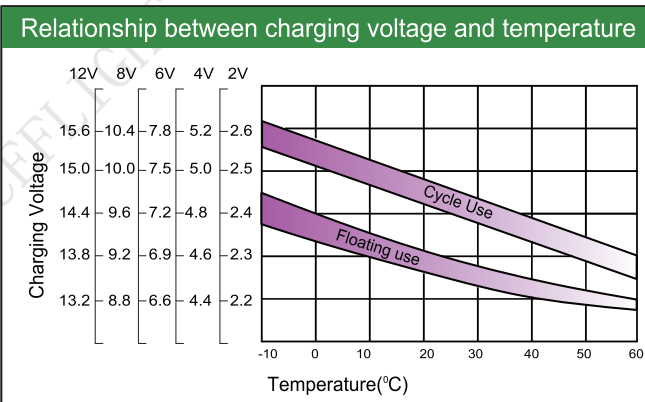
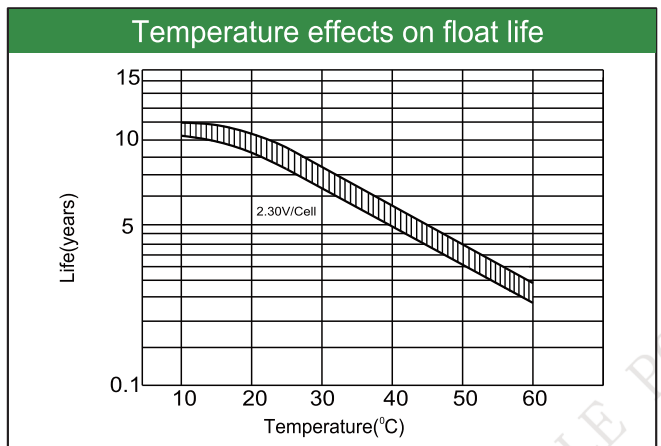
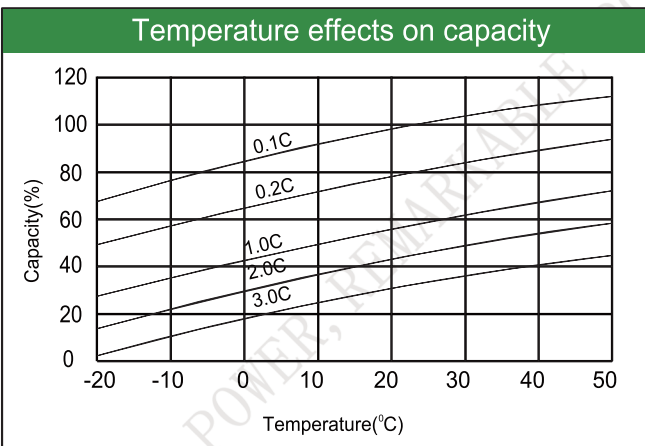
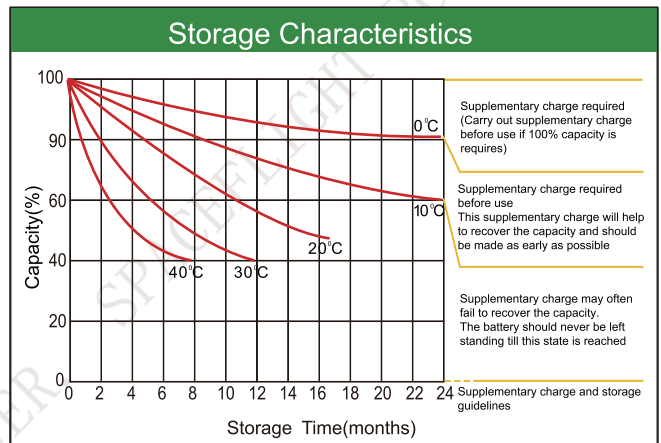
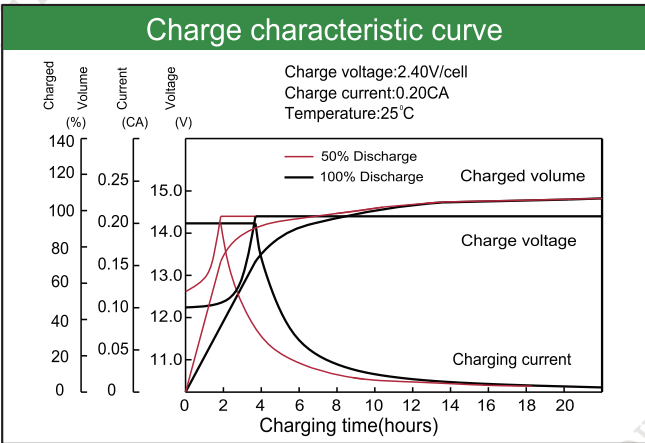
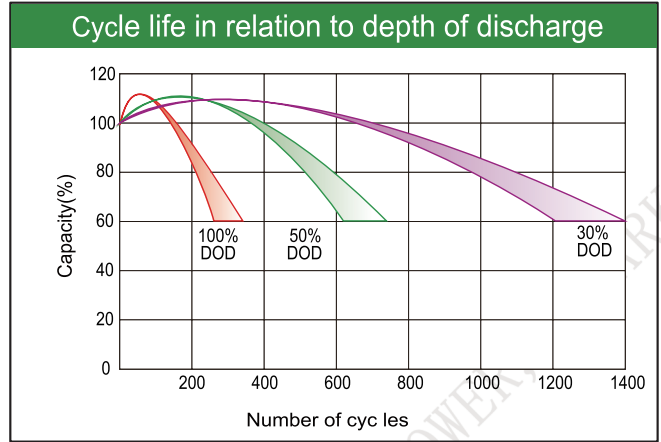
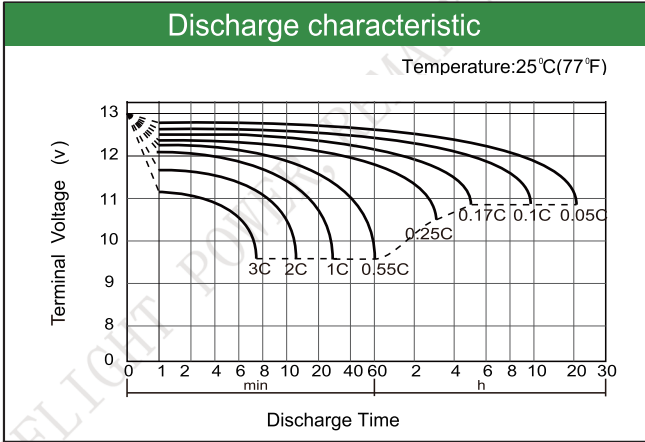

Factory address: Fukang Industrial Zone, Longnan, Ganzhou, Jiangxi Province, China.
 Shenzhen Office: RM208-210, Building D, Tongju industrial Park, No.4, Longping West Road, Longgang District, Shenzhen.
 TEL: +86-755-28288189 sales@sfbattery.com www.sfbattery.com