

HTH12-33W(12V8Ah)

HTH Series Battery

SPACEFLIGHT HTH series battery is High Rate battery based on advanced AGM technology, by using specially designed plates with more active materials which makes the battery can work under a heavy load discharge applications.

Applications

- Uninterruptible power supplies
- Telecommunication systems
- Communication equipments
- Emergency Power Systems
- Security system

General Features

- 5-8 years designed floating life(25 °C)
- Non-spillable construction
- Sealed and maintenance-free
- High reliability and stability
- High purity raw material: long life and low self-discharge

Standards

- Compliance with IEC, BS, JIS and EU standards
- UL, CE Certified
- ISO45001,ISO9001 and ISO14001 certified production facilities

Specifications

Rated Voltage	12V	
Nominal Capacity	33W/cell	(15min rate@1.67V)
Approx Weight	2.35kg±3%(5.18lbs)	
Terminal	F1/F2	
Rated Capacity(25°C)	8.0 Ah	(20hr,0.40A,10.5V)
	7.8 Ah	(10hr,0.78A,10.5V)
	7.0 Ah	(5hr,1.4A,10.5V)
	5.8 Ah	(1hr,5.8A,9.6V)
Max.Discharge Current	120A(5s)	
Max.Charge Current	2A	
Internal Resistance(25°C)	Approx 18.5mΩ	
Operating Temp.Range	Discharge	-20~60°C(-4~140°F)
	Charge	-10~50°C(14~122°F)
	Storage	-20~60°C(-4~140°F)
Nominal operating temperature	25±5°C	
Charge Voltage @25°C(77°F)	Cycle Use	Initial Charging Current less than 2A. Voltage 14.4V~15.0V at 25°C(77°F)Temp. Coefficient -30mV/°C
	Standby Use	Initial Charging Current less than 2A. Voltage 13.5V~13.8V at 25°C(77°F)Temp. Coefficient -20mV/°C
Temperature effects on capacity	40°C (104°F)	103%
	25°C (77°F)	100%
	0°C (32°F)	86%
	-15°C (5°F)	65%
Self Discharge(25°C)	Capacity after 3 months storage	91%
	Capacity after 6 months storage	82%
	Capacity after 12 months storage	65%



Dimensions

unit:mm

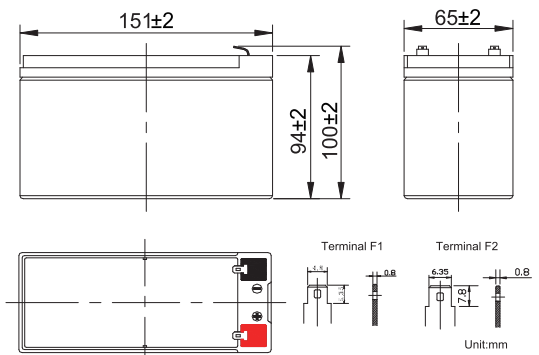

Length	151±2mm (5.94 inches)
Width	65±2mm (2.56 inches)
Container Height	94±2mm (3.70 inches)
Total Height	100±2mm (3.94 inches)

Battery Construction

Component	Positive plate	Negative plate	Container	Safety valve	Terminal	Separator	Electrolyte
Raw material	Lead dioxide	Lead	ABS(UL94-HB) or FR(UL94-V0)	Rubber	Copper	Fiberglass	Sulfuric acid

Constant Current Discharge (Amperes) at 25°C(77°F)

E.V/Time	5min	10min	15min	30min	60min	3h	5h	10h	20h
1.60V	/	25.8	18.8	10.2	5.8	2.31	1.57	0.81	0.43
1.65V	/	24.5	17.9	9.75	5.68	2.23	1.52	0.80	0.42
1.70V	/	23.2	16.9	9.25	5.55	2.15	1.46	0.79	0.42
1.75V	/	21.9	15.9	8.75	5.41	2.07	1.40	0.78	0.40
1.80V	/	20.4	14.9	8.20	5.35	1.99	1.33	0.77	0.40

Constant Power Discharge (Watts/cell) at 25°C(77°F)

E.V/Time	5min	10min	15min	30min	45min	60min	2h	3h	5h
1.60V	/	47.0	35.8	20.8	15.5	12.0	6.25	4.45	2.85
1.67V	/	43.5	33.0	19.0	14.5	11.5	5.90	4.23	2.75
1.70V	/	42.0	31.8	18.4	14.0	11.2	5.70	4.15	2.70
1.75V	/	39.5	30.8	17.2	13.2	10.7	5.40	4.0	2.62
1.80V	/	37.0	28.6	16.0	12.4	10.1	5.05	3.82	2.53

Note: The above characteristics data are average values obtained Within three charge/discharge cycles not the minimum.

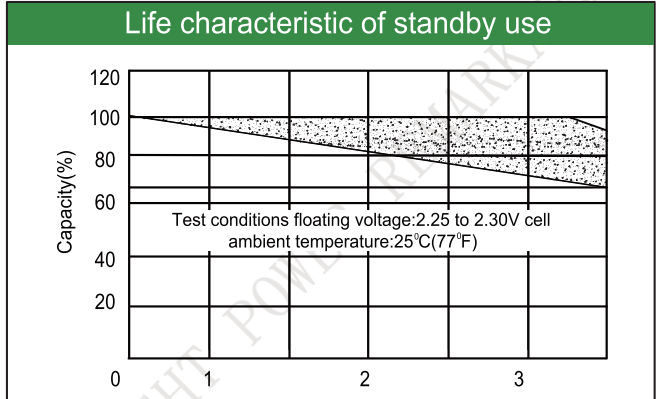
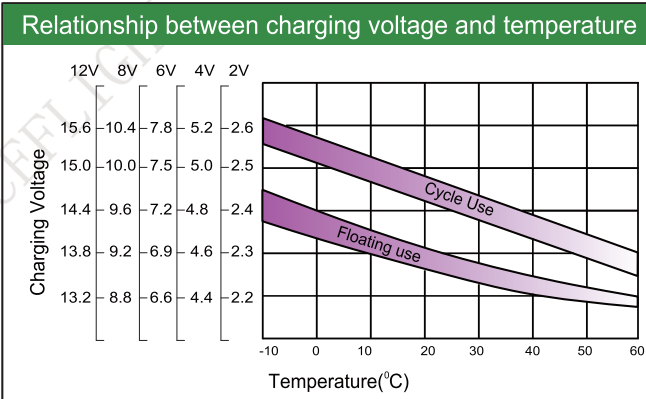
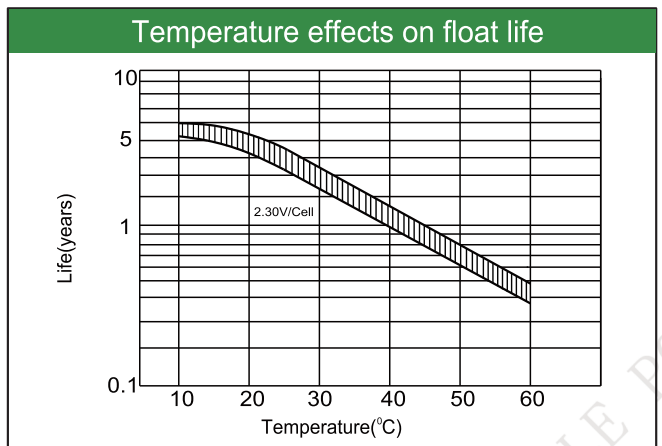
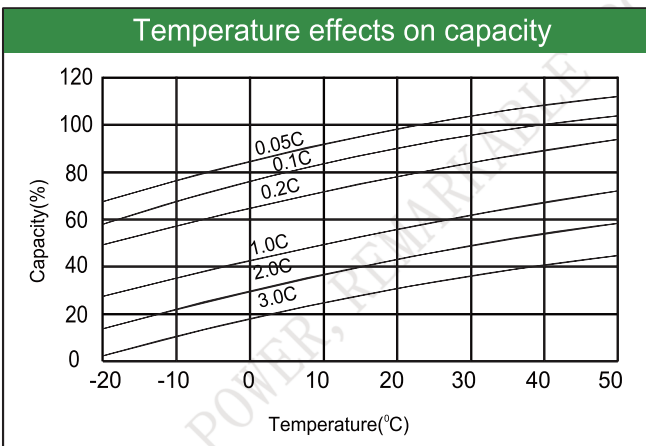
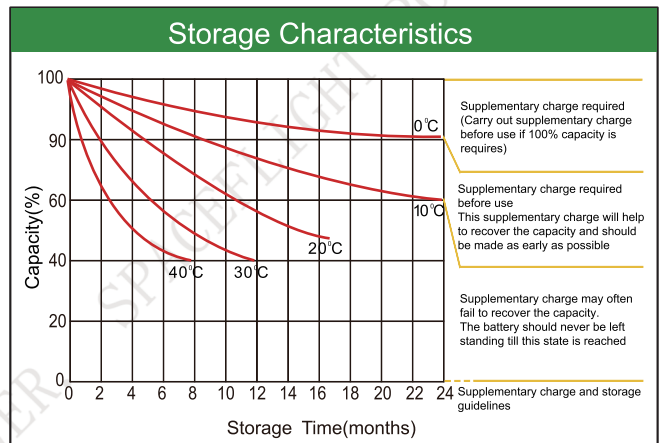
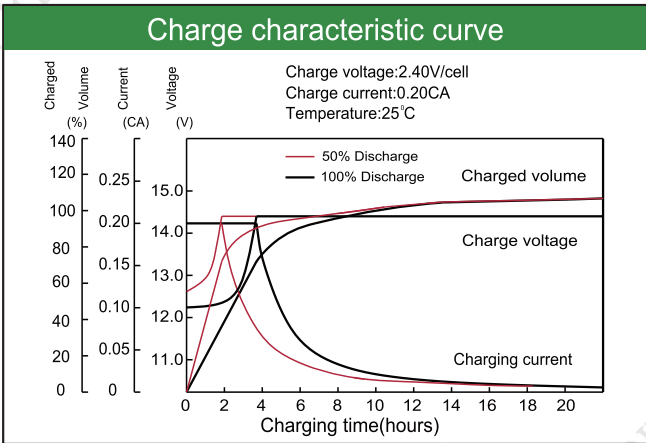
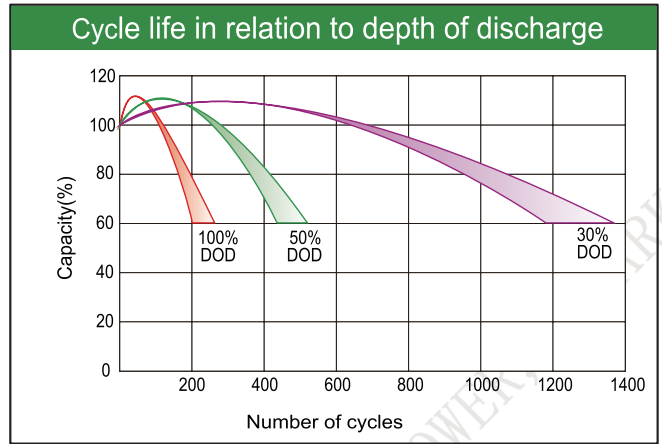
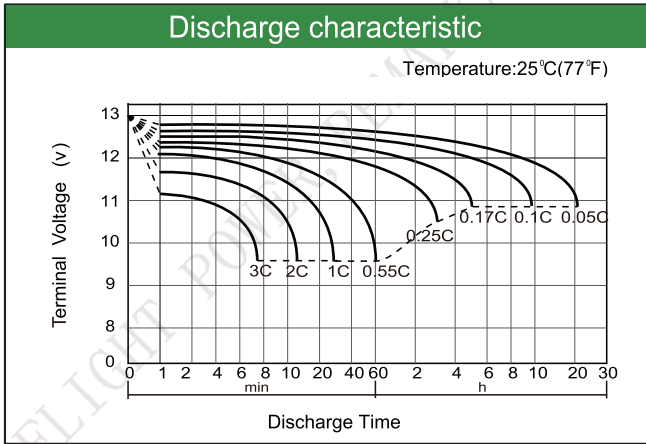

Factory address: Fukang Industrial Zone, Longnan, Ganzhou, Jiangxi Province, China.
 Shenzhen Office: RM208-210, Building D, Tongju industrial Park, No.4, Longping West Road, Longgang District, Shenzhen.
 TEL: +86-755-28288189 sales@sfbattery.com www.sfbattery.com