

HTG Series Battery

SPACEFLIGHT HTG Series Battery is hybrid GEL battery designed with deep cycle technology to give extra-durable cycle performance. HTG series battery with 20 years floating design life at 25°C.

Applications

- Solar and wind power systems
- Communication systems
- Uninterruptible power supplies
- Golf carts and buggies
- Alarm and security system
- Electric toy and wheelchairs, etc

General Features

- 20 years designed floating life(25 °C)
- Non-spillable construction
- Sealed and maintenance-free
- Excellent recovery from deep discharge
- High density active materials plates
- Longer Life and low self-discharge

Standards

- Compliance with IEC, BS, JIS and EU standards.
- UL, CE Certified
- ISO45001,ISO9001 and ISO14001 certified production facilities

Specifications

Rated Voltage	2V	
Nominal Capacity	200Ah	(C ₁₀ , 1.8V)
Approx Weight	13.5kg±3%(29.8lbs)	
Terminal	F10	
Rated Capacity(25°C)	200 Ah	(10hr,20A,1.80V)
	175 Ah	(5hr,35A,1.75V)
	159 Ah	(3hr,53A,1.70V)
	125 Ah	(1hr,125A,1.60V)
Max.Discharge Current	1000A(5s)	
Max.Charge Current	50A	
Internal Resistance(25°C)	Approx 1.2mΩ	
Operating Temp.Range	Discharge	-20~60 °C(-4~140 °F)
	Charge	-10~50 °C(14~122 °F)
	Storage	-20~60 °C(-4~140 °F)
Nominal operating temperature	25±5 °C	
Charge Voltage @25°C(77 °F)	Cycle Use	Initial Charging Current less than 50A. Voltage 2.4V~2.5V at 25°C(77°F)Temp. Coefficient -30mV/°C
	Standby Use	Initial Charging Current less than 50A. Voltage 2.25V~2.3V at 25°C(77°F)Temp. Coefficient -20mV/°C
Temperature effects on capacity	40 °C (104 °F)	103%
	25 °C (77 °F)	100%
	0 °C (32 °F)	86%
	-15 °C (5 °F)	65%
Self Discharge(25°C)	Capacity after 3 months storage	91%
	Capacity after 6 months storage	82%
	Capacity after 12 months storage	65%



Dimensions

unit:mm

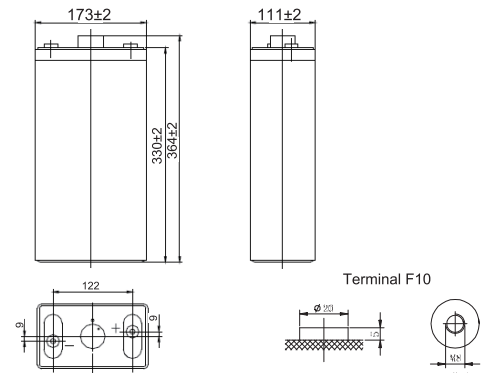

Length	173±2mm (6.81 inches)
Width	111±2mm (4.37 inches)
Container Height	330±2mm (13.0 inches)
Total Height	364±2mm (14.3 inches)

Battery Construction

Component	Positive plate	Negative plate	Container	Safety valve	Terminal	Separator	Electrolyte
Raw material	Lead dioxide	Lead	ABS(UL94-HB) or FR(UL94-V0)	Rubber	Copper	AGM	SiO ₂ +H ₂ SO ₄

Constant Current Discharge (Amperes) at 25°C(77°F)

E.V/Time	5min	10min	15min	30min	45min	1h	3h	5h	10h
1.60V	/	383	294	205	160	125	56.6	36.8	21.4
1.65V	/	364	281	196	153	121	54.8	36.0	21.2
1.70V	/	346	270	187	147	116	53.0	35.4	20.9
1.75V	/	327	257	177	139	111	50.0	35.0	20.5
1.80V	/	304	244	167	132	105	48.6	34.0	20.0

Constant Power Discharge (Watts/cell) at 25°C(77°F)

E.V/Time	5min	10min	15min	30min	45min	1h	2h	3h	5h
1.60V	/	670	529	374	302	245	146	106	78.0
1.65V	/	639	509	356	288	235	142	104	76.6
1.70V	/	607	489	336	273	224	137	101	75.1
1.75V	/	576	469	317	259	213	132	98.0	73.5
1.80V	/	564	456	307	244	201	126	94.7	71.7

Note: The above characteristics data are average values obtained Within three charge/discharge cycles not the minimum.

Discharge characteristic

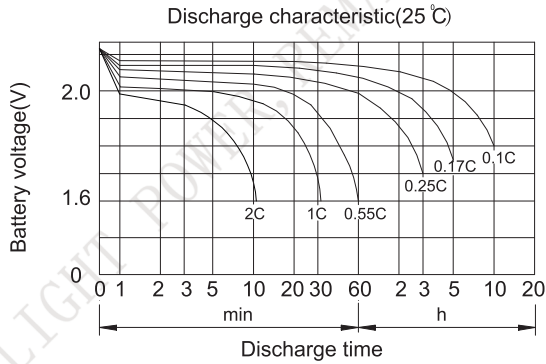

Cycle life in relation to depth of discharge

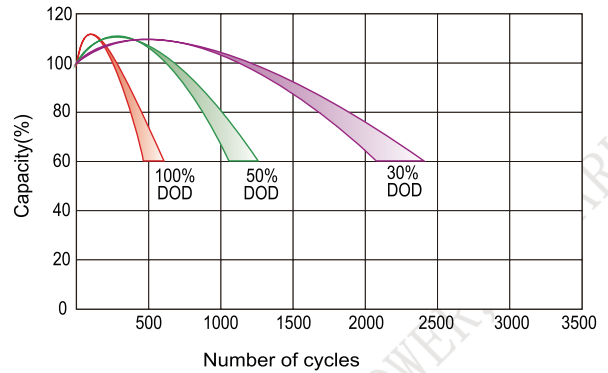

Charge characteristic curve

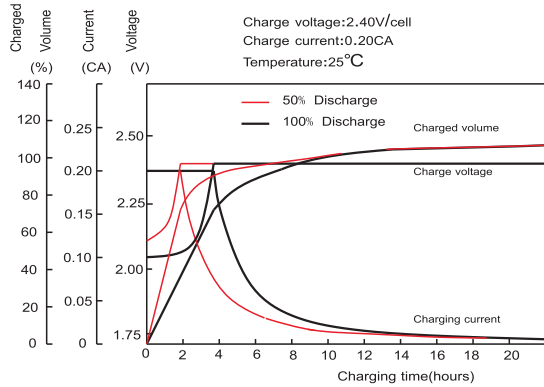

Storage Characteristics

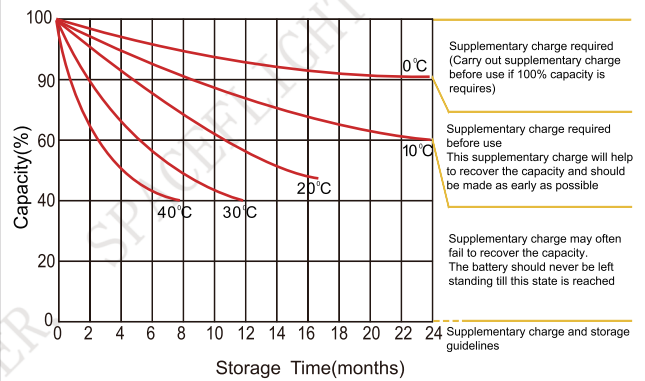

Temperature effects on capacity

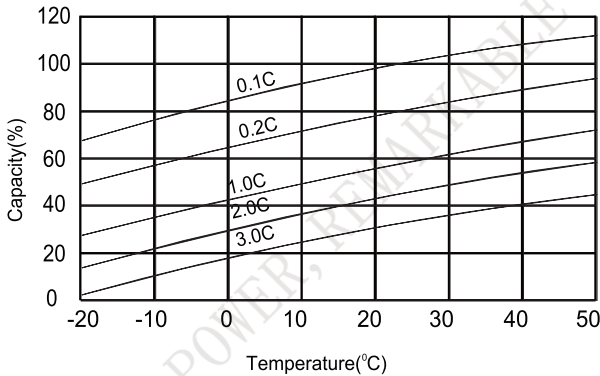

Temperature effects on float life

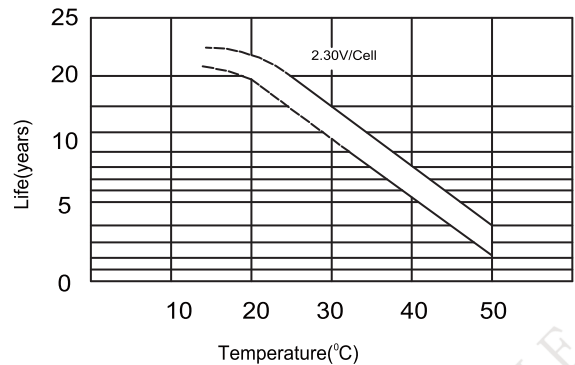

Relationship between charging voltage and temperature

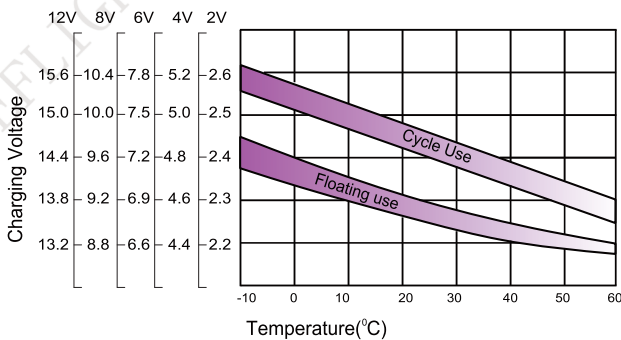

Life characteristic of standby use

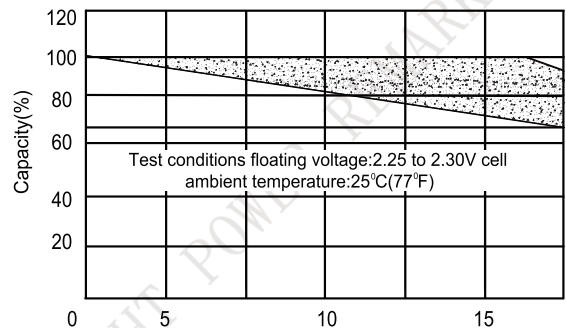

Factory address: Fukang Industrial Zone, Longnan, Ganzhou, Jiangxi Province, China.
Shenzhen Office: RM208-210, Building D, Tongju industrial Park, No.4, Longping West Road, Longgang District, Shenzhen.
TEL:+86-755-28288189 sales@sfbattery.com www.sfbattery.com